

# DATA: JUPITER 550 FAST GLAS 1 SIDE

( Alle mål er i mm )

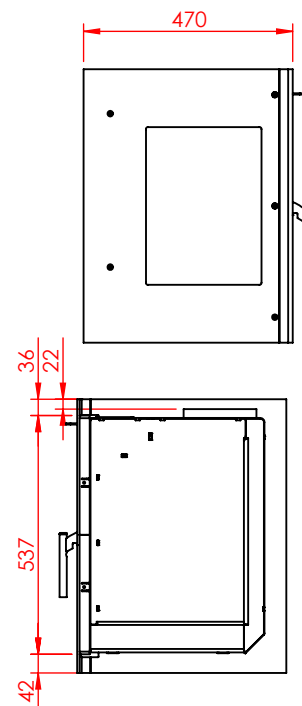

JUPITER 550 FAST GLAS 1 SIDE

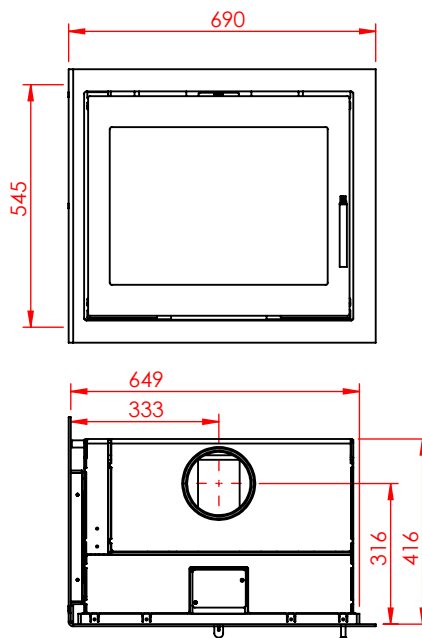
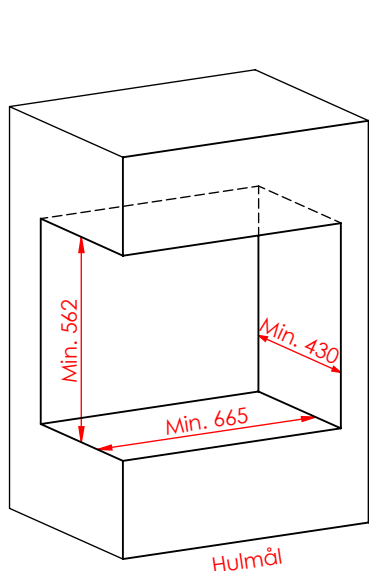
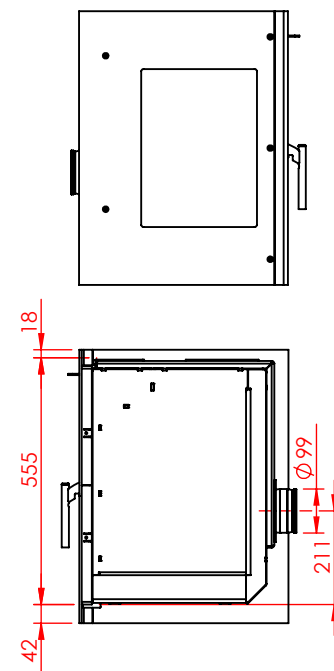
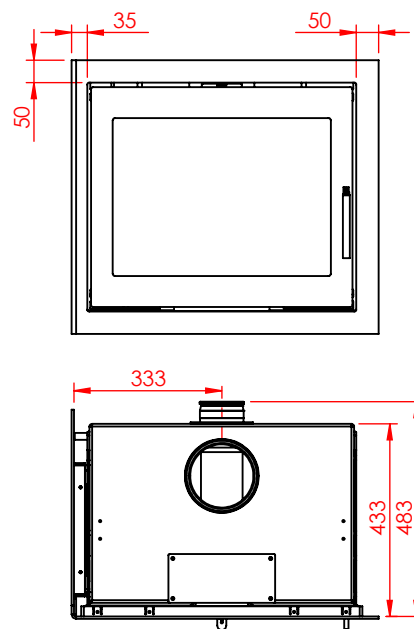
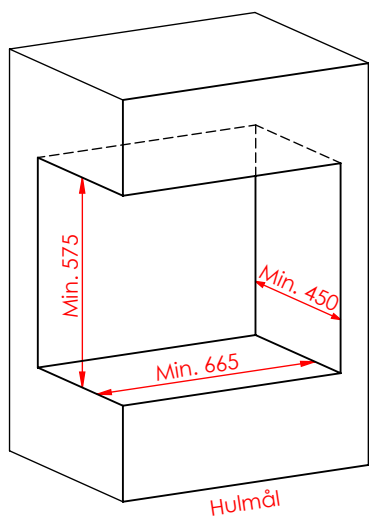

JUPITER 550 FAST GLAS 1 SIDE, FRISKLIFT BAG.

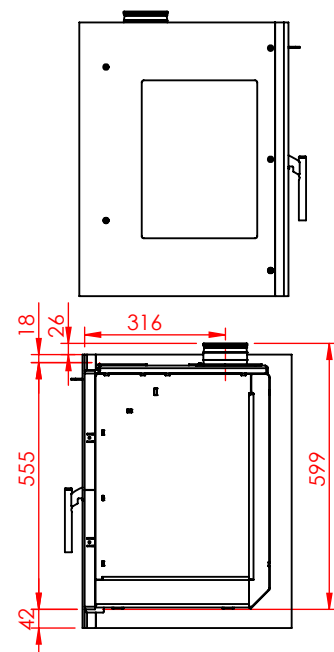
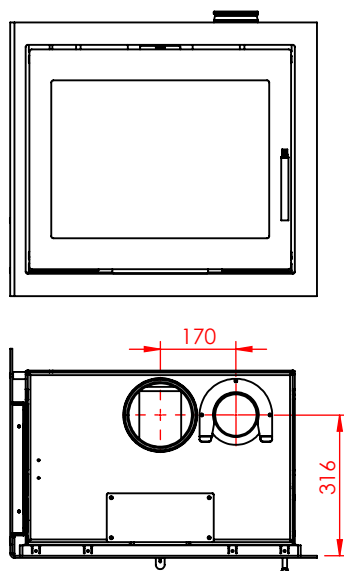
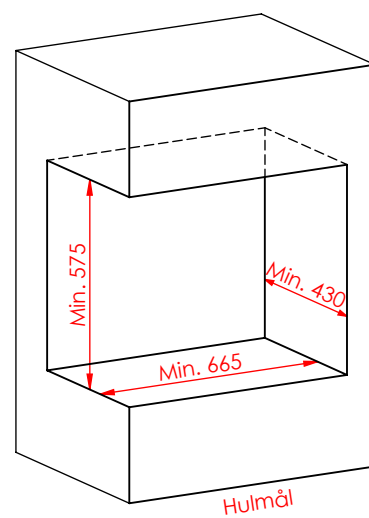

JUPITER 550 FAST GLAS 1 SIDE, FRISKLIFT TOP.

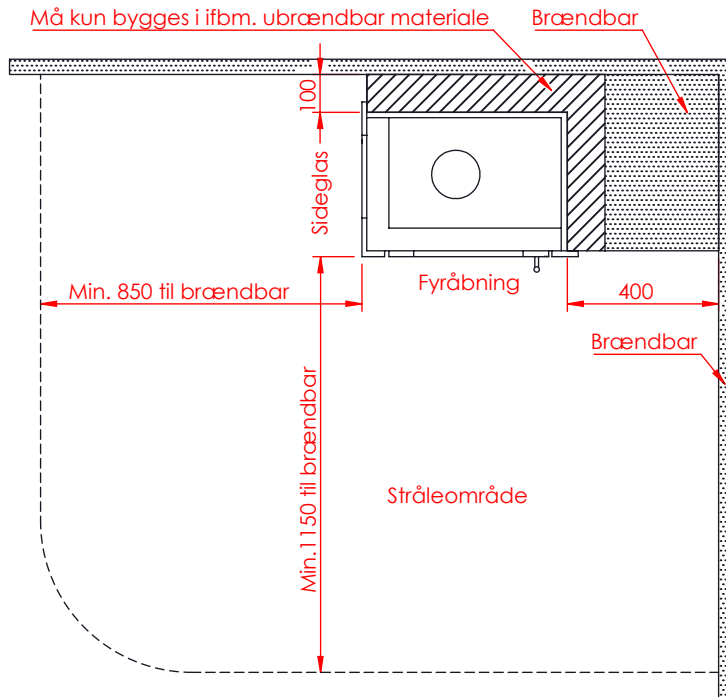

AFSTAND TIL BRÆNDBART.

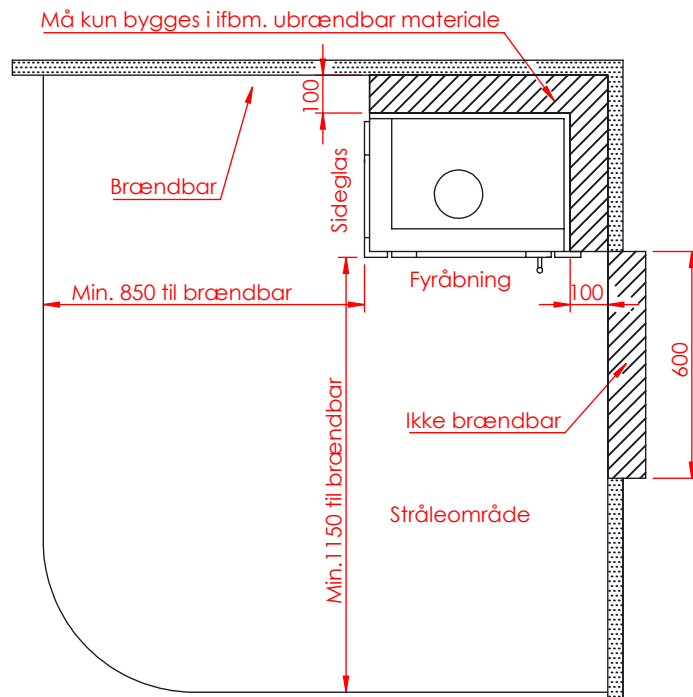

AFSTAND TIL BRÆNDBART.

# DATA: JUPITER 550 FAST GLAS 1 SIDE

( Alle mål er i mm )

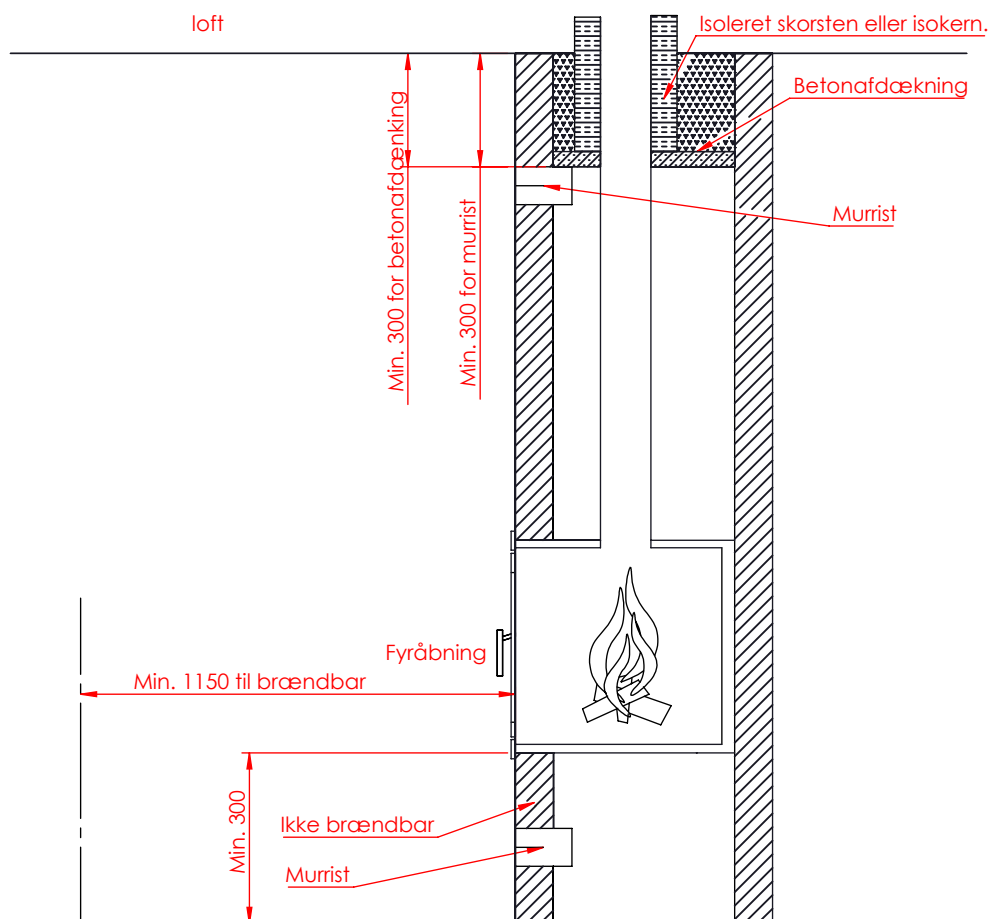

## AFSTAND TIL BRÆNDBART.

<b>Jupiter 550 med fast glas 1 side</b>	
Glasmål front:	503 x 367 mm.
Glasmål side:	274 x 367 mm.
Driftseffekt:	5 - 9 Kw
Nominel ydelse:	6,0 Kw
Røgstuds:	150 mm.
Virkningsgrad:	75 %
Ekstraudstyr:	Rysterist.
Ekstraudstyr:	Friskluft.